

Model Number	Nominal Size (Inches) W x H x D	Actual Size (Inches) W x H x D	Rated Air Flow (CFM)	Initial Resistance (IN W.G.)	Media Area (Square Feet)
PWG-117	10 x 20 x 1	9-3/4 x 19-3/4 x 3/4	425	.26	3.2
PWG-120	12 x 20 x 1	11-3/4 x 19-3/4 x 3/4	500	.26	3.5
PWG-110	12 x 24 x 1	11-3/8 x 23-3/8 x 3/4	600	.26	4.6
PWG-139	14 x 20 x 1	13-3/4 x 19-3/4 x 3/4	590	.26	4.2
PWG-141	14 x 25 x 1	13-3/4 x 24-3/4 x 3/4	730	.26	5.3
PWG-145	15 x 20 x 1	14-3/4 x 19-3/4 x 3/4	630	.26	4.5
PWG-101	16 x 20 x 1	15-1/2 x 19-1/2 x 3/4	670	.26	4.8
PWG-102	16 x 25 x 1	15-1/2 x 24-1/2 x 3/4	840	.26	6.0
PWG-112	18 x 24 x 1	17-1/2 x 23-1/2 x 3/4	900	.26	7.1
PWG-185	18 x 25 x 1	17-1/2 x 24-1/2 x 3/4	940	.26	7.0
PWG-103	20 x 20 x 1	19-1/2 x 19-1/2 x 3/4	840	.26	6.0
PWG-104	20 x 25 x 1	19-1/2 x 24-1/2 x 3/4	1050	.26	7.5
PWG-105	24 x 24 x 1	23-3/8 x 23-3/8 x 3/4	1200	.26	9.0
PWG-125	25 x 25 x 1	24-1/2 x 24-1/2 x 3/4	1310	.26	9.7

STANDARD CONSTRUCTION

1. White Electrostatic Needed Synthetic Media
2. 14.0 Pleats Per Foot
3. Expanded Metal Pleat Supports
4. Moisture Resistant Beverage Board Frame
5. Double Wall Frame

NOTES

1. Average Efficiency: 35-40% ASHRAE 52.1-1992
MERV 11 ASHRAE 52.2-1999
2. Final Resistance: 1.0" W.G.
3. Rated Velocity: 300 FPM
4. Class 2 Filter Per U.L. Standard 900
5. Maximum Operating Temperature: 200 deg. F

ONE SOURCE FOR AIR FILTRATION PRODUCTS
 P.O. Box 32578
 Louisville, KY 40232
 P: 502-969-2304
 F: 502-961-0930

CONTACT FACTORY TO VERIFY REVISION LEVEL

TOLERANCES UNLESS OTHERWISE SPECIFIED

FRACTIONAL
DECIMAL
ANGLES

ALL DIMENSIONS IN INCHES

DRAWING NAME

POWERGUARD (1" DEPTH)

APPROVED BY

KC

SPECIFICATION NO.

MKT-B-00158

PAGE

1 OF 1

SCALE

NONE

DWG. SIZE

A

REVISION

NEW

REVISION DATE

10-11-00

CONFIDENTIAL - DO NOT COPY. THIS MATERIAL IS TRADE SECRET AND PROPRIETARY BEING EXCLUSIVELY OWNED BY AIRGUARD. THE EXPRESSION OF THE INFORMATION CONTAINED HEREIN IS PROTECTED UNDER FEDERAL COPYRIGHT LAWS AND ALL COPYING IS PROHIBITED AND MAY BE SUBJECT TO CRIMINAL PENALTIES.

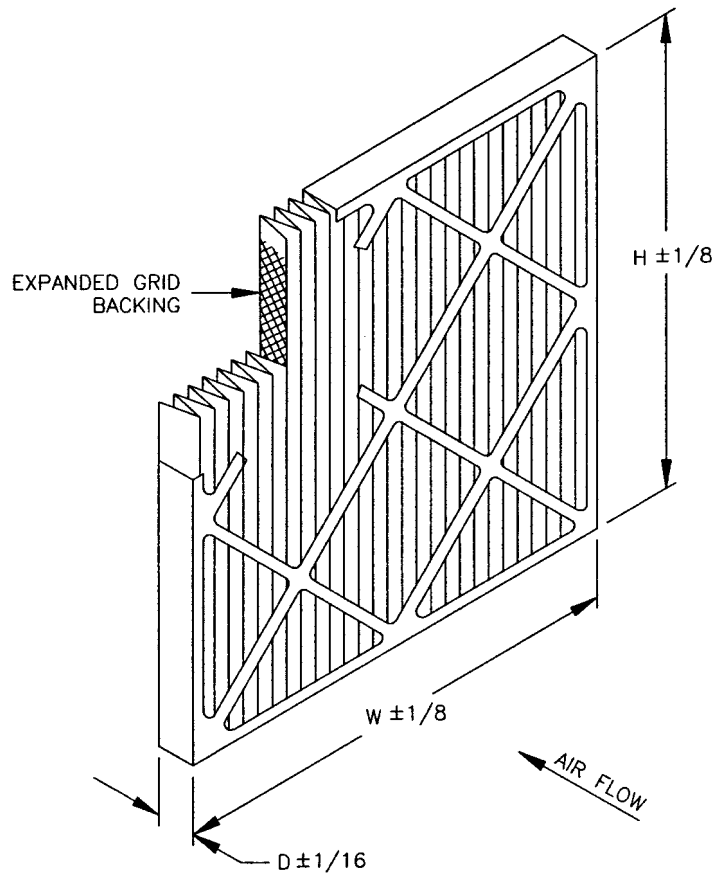

Model Number	Nominal Size (Inches) W x H x D	Actual Size (Inches) W x H x D	Rated Air Flow (CFM)	Initial Resistance (IN W.G.)	Media Area (Square Feet)
PWG-217	10 x 20 x 2	9-3/4 x 19-3/4 x 1-3/4	700	.38	5.7
PWG-220	12 x 20 x 2	11-3/4 x 19-3/4 x 1-3/4	840	.38	6.8
PWG-210	12 x 24 x 2	11-3/8 x 23-3/8 x 1-3/4	1000	.38	8.3
PWG-239	14 x 20 x 2	13-3/4 x 19-3/4 x 1-3/4	980	.38	8.0
PWG-241	14 x 25 x 2	13-3/4 x 24-3/4 x 1-3/4	1220	.38	10.0
PWG-298	15 x 27 x 2	14-1/2 x 26-3/4 x 1-3/4	1350	.38	11.8
PWG-245	15 x 20 x 2	14-3/4 x 19-3/4 x 1-3/4	1050	.38	8.5
PWG-201	16 x 20 x 2	15-1/2 x 19-1/2 x 1-3/4	1120	.38	10.1
PWG-216	16 x 24 x 2	15-1/2 x 23-1/2 x 1-3/4	1340	.38	11.8
PWG-202	16 x 25 x 2	15-1/2 x 24-1/2 x 1-3/4	1400	.38	12.5
PWG-280	18 x 20 x 2	17-3/4 x 19-3/4 x 1-3/4	1250	.38	10.6
PWG-212	18 x 24 x 2	17-1/2 x 23-1/2 x 1-3/4	1500	.38	12.7
PWG-285	18 x 25 x 2	17-1/2 x 24-1/2 x 1-3/4	1570	.38	13.1
PWG-203	20 x 20 x 2	19-1/2 x 19-1/2 x 1-3/4	1400	.38	12.2
PWG-211	20 x 24 x 2	19-3/8 x 23-3/8 x 1-3/4	1670	.38	14.7
PWG-204	20 x 25 x 2	19-1/2 x 24-1/2 x 1-3/4	1750	.38	15.3
PWG-205	24 x 24 x 2	23-3/8 x 23-3/8 x 1-3/4	2000	.38	17.6
PWG-225	25 x 25 x 2	24-1/2 x 24-1/2 x 1-3/4	2170	.38	19.2

STANDARD CONSTRUCTION

1. White Electrostatic Needled Synthetic Media
2. 14.3 Pleats Per Foot
3. Expanded Metal Pleat Supports
4. Moisture Resistant Beverage Board Frame
5. Double Wall Frame

NOTES

1. Average Efficiency: 35-40% ASHRAE 52.1-1992
MERV 11 ASHRAE 52.2-1999
2. Final Resistance: 1.0" W.G.
3. Rated Velocity: 500 FPM
4. Class 2 Filter Per U.L. Standard 900
5. Maximum Operating Temperature: 200 deg. F

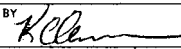
 ONE SOURCE FOR AIR FILTRATION PRODUCTS P.O. Box 32578 Louisville, KY 40232 P: 502-969-2304 F: 502-961-0930	TOLERANCES UNLESS OTHERWISE SPECIFIED		DRAWING NAME POWERGUARD (2" DEPTH)		
	FRACTIONAL DECIMAL ANGLES	APPROVED BY 	SPECIFICATION NO. MKT-B-00159	PAGE 1 OF 1	REVISION DATE 10-11-00
CONTACT FACTORY TO VERIFY REVISION LEVEL		SCALE NONE	DWG. SIZE A	REVISION NEW	REVISION DATE 10-11-00
ALL DIMENSIONS IN INCHES					

CONFIDENTIAL - DO NOT COPY. THIS MATERIAL IS TRADE SECRET AND PROPRIETARY BEING EXCLUSIVELY OWNED BY AIRGUARD. THE EXPRESSION OF THE INFORMATION CONTAINED HEREIN IS PROTECTED UNDER FEDERAL COPYRIGHT LAWS AND ALL COPYING IS PROHIBITED AND MAY BE SUBJECT TO CRIMINAL PENALTIES.

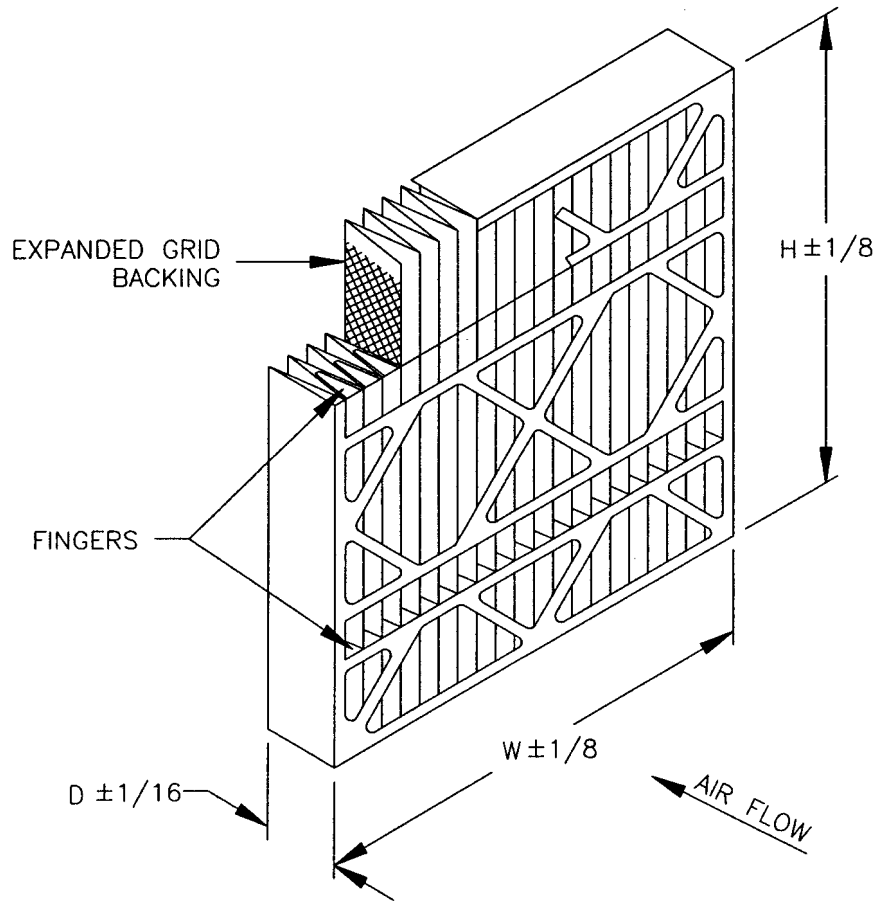

Model Number	Nominal Size (Inches) W x H x D	Actual Size (Inches) W x H x D	Rated Air Flow (CFM)	Initial Resistance (IN W.G.)	Media Area (Square Feet)
PWG-410	12 x 24 x 4	11-3/8 x 23-3/8 x 3-3/4	1000	.30	14.4
PWG-498	15 x 27 x 4	14-1/2 x 26-3/4 x 3-3/4	1350	.30	19.4
PWG-401	16 x 20 x 4	15-1/2 x 19-1/2 x 3-3/4	1120	.30	15.0
PWG-402	16 x 25 x 4	15-1/2 x 24-1/2 x 3-3/4	1400	.30	18.6
PWG-412	18 x 24 x 4	17-1/2 x 23-1/2 x 3-3/4	1500	.30	20.4
PWG-403	20 x 20 x 4	19-1/2 x 19-1/2 x 3-3/4	1400	.30	19.0
PWG-411	20 x 24 x 4	19-3/8 x 23-3/8 x 3-3/4	1670	.30	22.8
PWG-404	20 x 25 x 4	19-1/2 x 24-1/2 x 3-3/4	1750	.30	23.5
PWG-405	24 x 24 x 4	23-3/8 x 23-3/8 x 3-3/4	2000	.30	27.6
PWG-424	25 x 29 x 4	24-1/2 x 28-1/2 x 1-3/4	2430	.30	32.4

STANDARD CONSTRUCTION

1. White Electrostatic Needed Synthetic Media
2. 10.8 Pleats Per Foot
3. Expanded Metal Pleat Supports
4. Moisture Resistant Beverage Board Frame
5. Double Wall Frame
6. (2) Rows of Fingers on Air Entering Side

NOTES

1. Average Efficiency: 35-40% ASHRAE 52.1-1992
MERV 11 ASHRAE 52.2-1999
2. Final Resistance: 1.0" W.G.
3. Rated Velocity: 500 FPM
4. Class 2 Filter Per U.L. Standard 900
5. Maximum Operating Temperature: 200 deg. F

AIRGUARD ONE SOURCE FOR AIR FILTRATION PRODUCTS
 P.O. Box 32578
 Louisville, KY 40232
 P: 502-969-2304
 F: 502-961-0930

CONTACT FACTORY TO VERIFY REVISION LEVEL

TOLERANCES UNLESS OTHERWISE SPECIFIED

FRACTIONAL
 DECIMAL
 ANGLES

ALL DIMENSIONS IN INCHES

DRAWING NAME: **PowerGuard (4" DEPTH)**

APPROVED BY: *KCA* SPECIFICATION NO. MKT-B-00160 PAGE 1 OF 1

SCALE: NONE DWG. SIZE: A REVISION: NEW REVISION DATE: 10-11-00

CONFIDENTIAL - DO NOT COPY. THIS MATERIAL IS TRADE SECRET AND PROPRIETARY BEING EXCLUSIVELY OWNED BY AIRGUARD. THE EXPRESSION OF THE INFORMATION CONTAINED HEREIN IS PROTECTED UNDER FEDERAL COPYRIGHT LAWS AND ALL COPYING IS PROHIBITED AND MAY BE SUBJECT TO CRIMINAL PENALTIES.