

Model Number	Nominal Size (Inches) W x H x D	Actual Size (Inches) W x H x D	Rated Air Flow (CFM)	Initial Resistance (IN W.G.)	Media Area (Square Feet)
SC-210	12 x 24 x 2	11-3/8 x 23-3/8 x 1-3/4	1000	.33	5.0
SC-201	16 x 20 x 2	15-1/2 x 19-1/2 x 1-3/4	1120	.33	5.2
SC-202	16 x 25 x 2	15-1/2 x 24-1/2 x 1-3/4	1400	.33	6.5
SC-203	20 x 20 x 2	19-1/2 x 19-1/2 x 1-3/4	1400	.33	6.8
SC-211	20 x 24 x 2	19-3/8 x 23-3/8 x 1-3/4	1670	.33	8.0
SC-204	20 x 25 x 2	19-1/2 x 24-1/2 x 1-3/4	1750	.33	8.4
SC-205	24 x 24 x 2	23-3/8 x 23-3/8 x 1-3/4	2000	.33	9.9

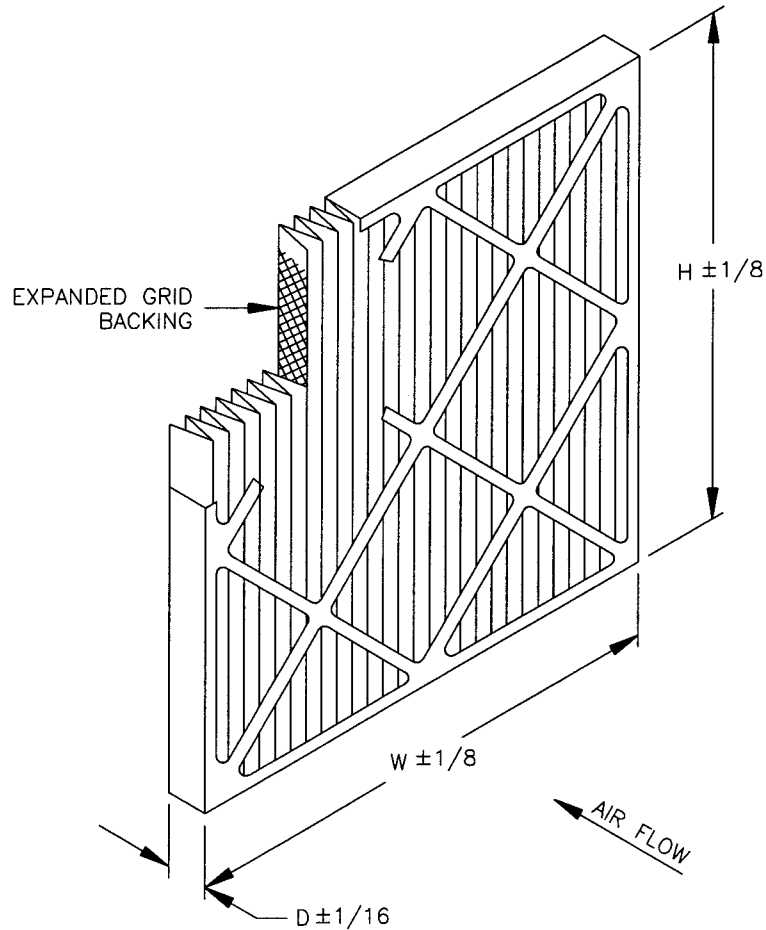

#### STANDARD CONSTRUCTION

1. Green Cotton / Polyester High Loft Media
2. 8.0 Pleats Per Foot
3. Expanded Metal Pleat Supports
4. Moisture Resistant Beverage Board Frame
5. Die-Cut Double Wall Frame

#### NOTES

1. Average Efficiency: 25-30% ASHRAE 52.1-1992  
MERV 6 ASHRAE 52.2-1999
2. Final Resistance: 1.0" W.G.
3. Rated Velocity: 500 FPM
4. Class 2 Filter Per U.L. Standard 900
5. Maximum Operating Temperature: 225 deg. F



ONE SOURCE  
FOR  
AIR FILTRATION  
PRODUCTS

P.O. Box 32578  
Louisville, KY 40232  
P: 502-969-2304  
F: 502-961-0930

CONTACT FACTORY TO  
VERIFY REVISION LEVEL

TOLERANCES  
UNLESS OTHERWISE SPECIFIED

FRACTIONAL  
DECIMAL  
ANGLES

ALL DIMENSIONS IN INCHES

DRAWING NAME

TYPE SC PLEAT (2" DIE-CUT FRAME)

APPROVED BY

*H. O.*

SPECIFICATION NO.

MKT-B-00202

PAGE

1 OF 1

SCALE

NONE

DWG. SIZE

A

REVISION

A

REVISION DATE

06-18-02

CONFIDENTIAL - DO NOT COPY. THIS MATERIAL IS TRADE SECRET AND PROPRIETARY BEING EXCLUSIVELY OWNED BY AIRGUARD. THE EXPRESSION OF THE INFORMATION CONTAINED HEREIN IS PROTECTED UNDER FEDERAL COPYRIGHT LAWS AND ALL COPYING IS PROHIBITED AND MAY BE SUBJECT TO CRIMINAL PENALTIES.